

USER MANUAL

(Version 1.0)



General Type Hot Plate Welding Machine

I System construction

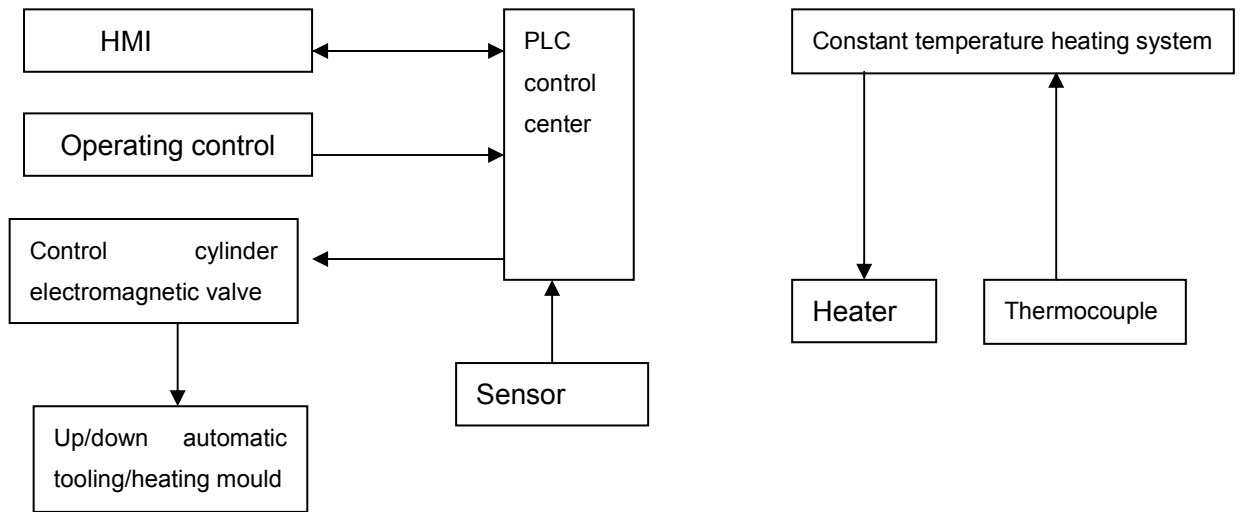

II Equipment external construction

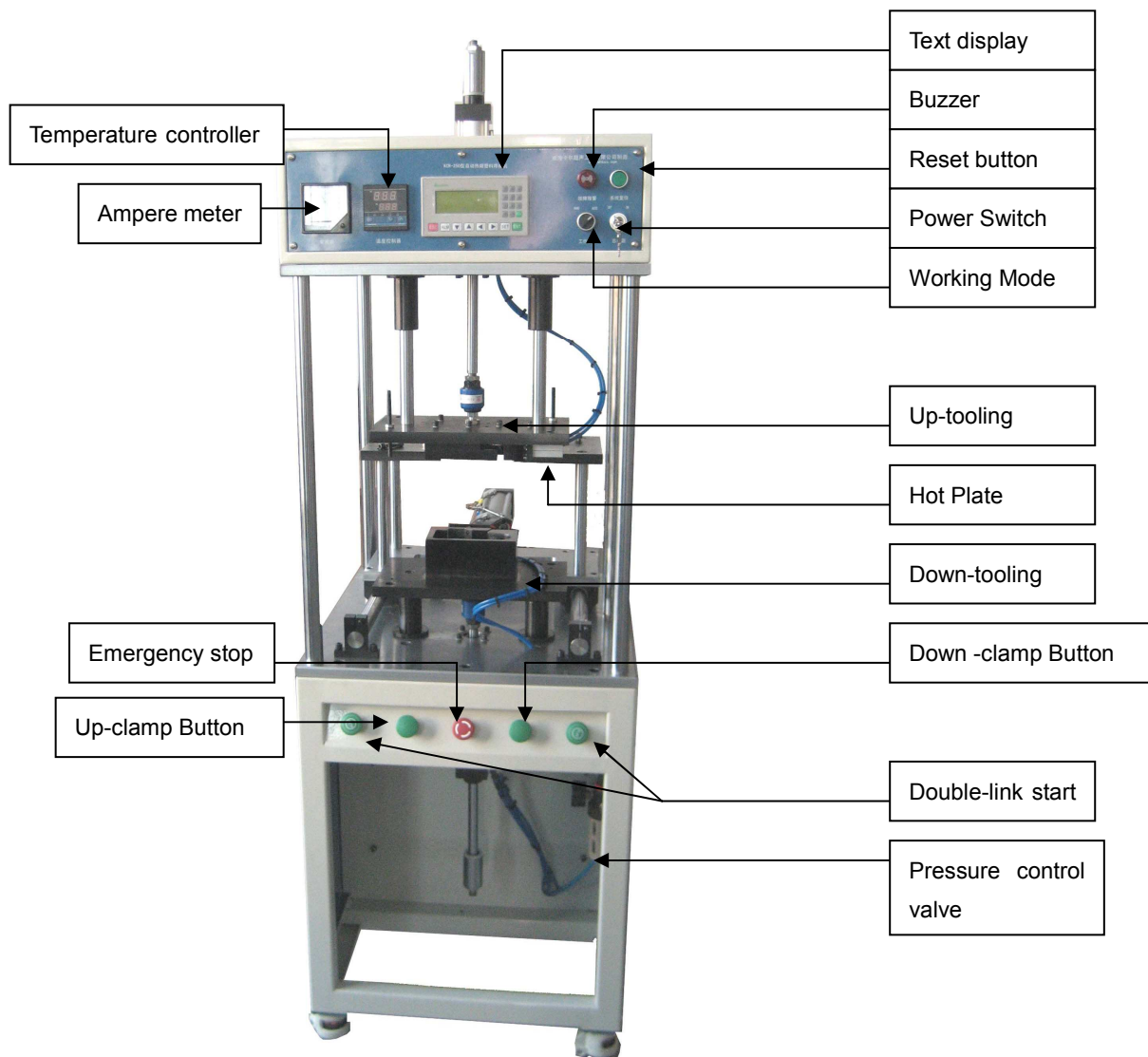

III Equipment working ambient

- Operating voltage: AC220V±10%
- Power: 2400W
- Power supply noise: not exceed 100Vp_p
- Allowed momentary power stop: less than 10ms
- Operating temperature: 0 ~ 50℃
- Equipment storage temperature: -10 ~ 60℃
- Ambient humidity: 20 ~ 70%(non-condensation)
- Around no vibration existing
- Around no dust and no corrosive gas

IV Logical progress of equipment action

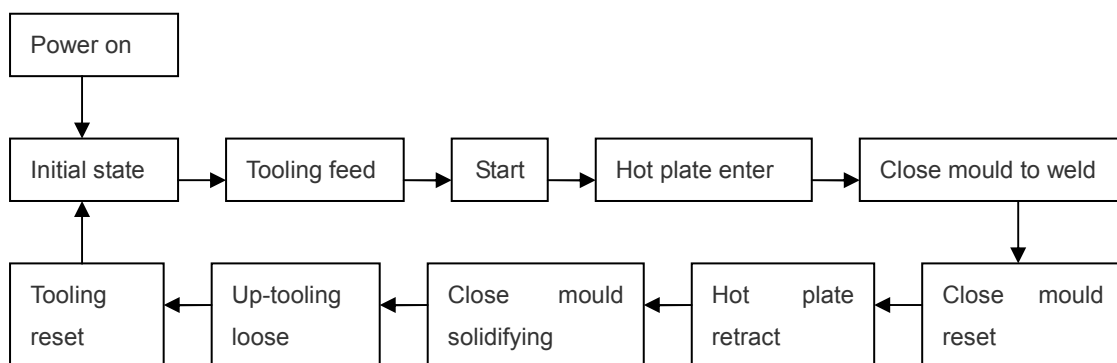

V Cooperating of equipment

1. Working mode of equipment

- To choose automatic mode or manual mode by pressing working mode button.
- Under manual operating mode, the equipment takes each action by pressing operating button once. This working mode is used for debugging equipment.
- Under automatic operating mode, the equipment complete one working circle by pressing operating button once. This working mode is used for normal production.

2. The functions of up-clamp button and down-clamp button

After pressed up-clamp button 0.5 s only, up tooling take an action of vacuum exhaust and suck the workpieces. To press again, vacuum

exhaust is releasing.

After pressed down-clamp button 0.5 s only, down tooling take an action of vacuum exhaust and suck the workpieces. To press again, vacuum exhaust is releasing.

To press the up and down clamp buttons 0.5s at the same time, under the automatic operating mode, the up and down tooling close mould automatically, up and down jigs take an action of vacuum exhaust, and when workpieces is sucked successfully, the up and down tooling will separate. Under the manual operating mode, press the up and down clamp button at the same time, the equipment will run the single action of automatic operating mode.

Remark: when the up and down clamp buttons be pressed at the same time, it must be ensure that the up and down's vacuum exhaust are not sucked, otherwise the equipment has no reaction.

Only up and down vacuum exhaust is sucking simultaneously, and then press start button, equipment will operate normally.

3. Function of emergency button

- Press the emergency button during welding, the equipment will return to last welding step. And press the emergency button during pressure maintaining state, up tooling jigs will be loosen and return to the last working step.
- Press emergency button, the operating buttons is shielded and can't work.
- Press emergency button can cancel alarm.

4. Function of grating

Under automatic mode, if the grating is broken during automatic feeding and normally welding process, the equipment's operating will return to the last working step and stop operating. To press start button, the equipment will continue to operate.

Under manual mode, the grating doesn't work, please be careful.

5. Function of resetting button:

To press the resetting button, equipment will back to initial state.

6. Main switch of power supply:

When the air switch on the switchboard is open, the main switch plays a part in supplying power to the controlling closed loop.

7. Text displayer

```

State: Auto Feeding
Melt Time: 12.3 S
Hold Time: 12.3 S
  
```

```

Delay Time: 12.3 S
Open Time: 12.3 S
Alarm Time: 12.3 S
  
```

```

Action Time: 12.3 S
WeiHai Kaer Sonic Power
Company Limited
Tel:0631-5690111
  
```

State: display current working state and working mode (automatic/manual) of hot plate welding machine.

Melt Time: the melting time of workpiece.

Hold Time: Welding solidify and dwell time

Delay Time: Relative to down-mould, the delay melting time of up-mould

Open Time: Under keep pressure state, up-mould's clamped cylinder loosing time. Jigs' loosing time will be less than hold time.

Alarm Time: Each alarming detection state's buffering time, it should be a little more than each step mechanical operating time.

Action Time: under automatic mode, when the workpieces are put automatically, the required time of up and down tooling closing mould.

Working state includes several kinds of states as following:

Ini State: initial state, when equipment doesn't start to weld, the state of all the cylinder retracting.

Stop: emergency stop state, emergency button is pressed and grating is broken during welding progress.

Feeding: Put workpieces on the tooling and finished fixation state.

Welding: after pressing start button, the equipment moves into the normal welding state.

HP extend: Hot plate extending state

Melt State: Up and down tooling close mould, and workpieces moves into melt state.

Melt Over: Heat melting time is over, up and down tooling separated state.

HP Retract: state of hot plate back to original position

Hold State: when the hot melting progresses is finished, up and down toolings close mould, the workpieces move into the state of solidifying and keeping pressure.

Resetting: Resetting state.

Text displayer instruction:

[ESC] Key: whichever the state of displayer, once press this key, text

displayer will back to initial menu.

[ALM] key: alarm list key, press this key will switch to alarm list menu.

[SET] key: modifying parameters by pressing this key. Current modified parameter will be anti-color displayed, and modified digit flashing displayed. To press **[SET]** before press the **[ENT]** key, the current modifying will be canceled, and continue to revise the next data.

[ENT] key: save the modified data, and continue to revising the next. After modifying last data in this menu, it will esc setting state.

[CLR] key: clear the chosen area during modifying data.

Numeric key: in the state of setting parameters, the modified digits change to corresponding key value.

[^][v] key: switch display menu. In the state of setting parameters, it can revise corresponding digits value.

[<][>] key: In the state of setting parameters, press these keys can choose the modified digits.

8. Temperature controller

Temperature controller plays a part in controlling hot plate's temperature. Press **[set]** key, adjusting temperature value by press \wedge , \vee . After adjusted, press **[set]** for confirming.

9. Operating instruction of equipment

- **Automatic mode**

At first, ensure that equipment in initial state, put on the workpieces on down-tooling and flat tooling. And move flat tooling on the down tooling, then press 'up-clamp button' and 'down-clamp button' for more than 0.5 second. The equipment will close mould for fixing workpieces automatically. After up and down tooling return to the original position, take away the flat tooling from the down tooling. If workpieces is improper fixed, it can be relieved by pressing resetting button, or pressing 'up-clamp button', 'down-clamp button' separately.

Flat tooling is taken away, and workpieces are fixed well, press double start button, equipment will operate as per the pre-set parameters. The emergency button can be pressed for suspending and returning to the last operating step. Or reset the equipment by

pressing reset button.

- **Manual mode:**

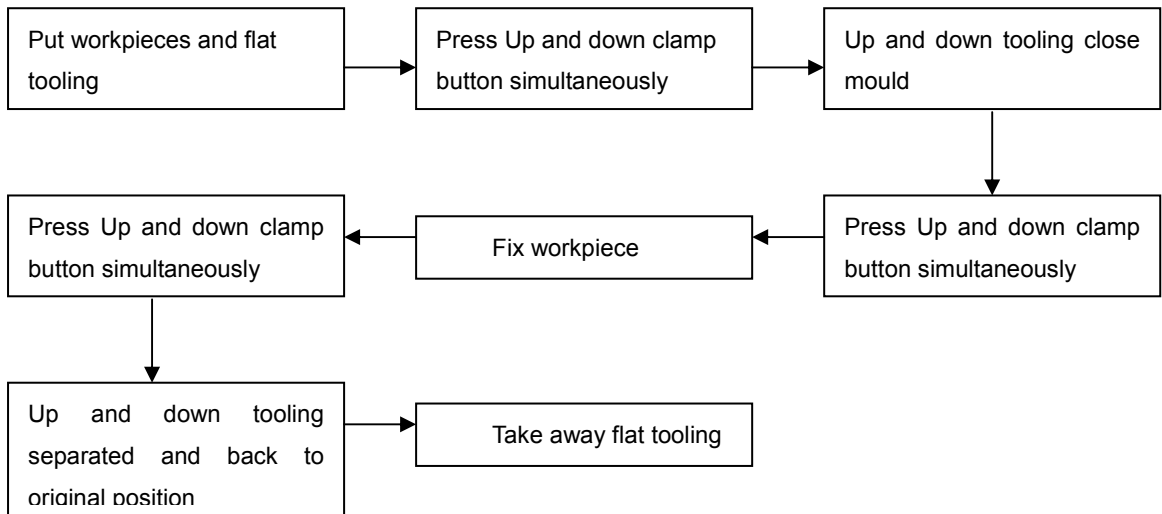

After the workpieces are fixed:

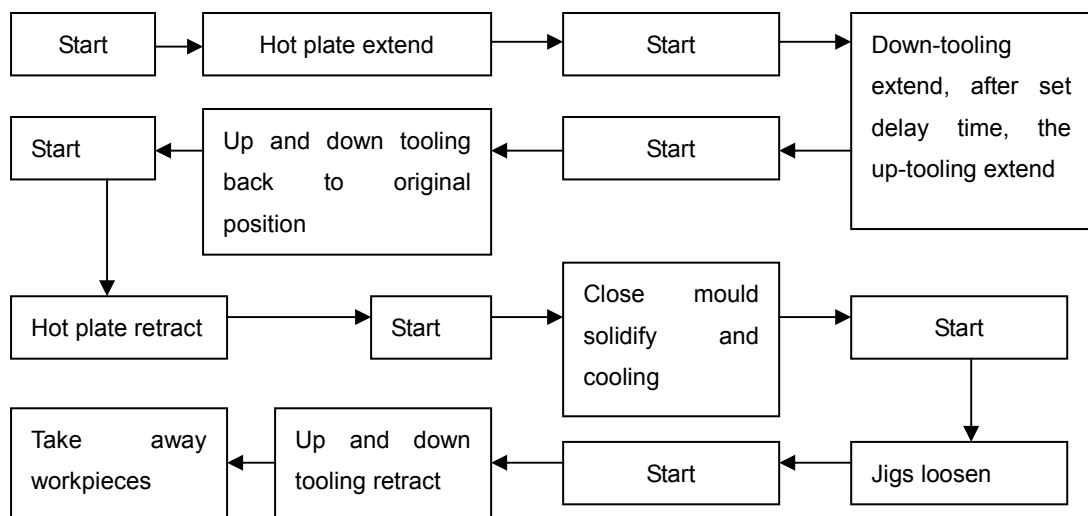

After moved into manual mode from automatic mode, the equipment will move to automatic mode and operate automatically.

VI Equipment alarm information

1. Cylinder extend-retract alarm

Cylinder extend-retract alarm include hot plate extend-retract alarm, up tooling extend-retract alarm, and down tooling extend-retract alarm.

The reason maybe is insufficient air pressure, cylinder is stuck, magnetic switch failure or correspondence magnetic valve failure etc.

2 .Alarm to jigs loosen time more than dwell time

The reason is jigs loosen time more than dwell time, please reset jigs loosen time parameter or dwell time parameter.

VII Precautions for Application

- Earthing before operating, earth resistance should be less than 1 ohm.
- Operate in normal ambient.
- Dedust and oiling and other maintenances at regular time and intervals.
- Keep body (hands, head etc.) away from moving parts of equipment!
- Operating and debugging equipment, please wear protective gloves.
- Wipe and clean hot plate with proper heat insulation for avoiding burning operators.
- When the equipment is not use or debug please close power switch and press emergency button.
- When abnormal occurrences appeared, press emergency button immediately.

VIII Special statement

1. The contents of this manual are only for reference. Please make enquiry to service hotline where there is anything unclear: 86-631-5690111.
2. China Weihai Kaer Sonic Power Co., Ltd. reserves the right to interpret of this manual.